

Driveway Mechanic: The Care & Feeding Of Your Automatic Climate Control

by George Murphy, Smoky Mountain Section

Problems with the automatic climate control system of 1976-1981 models are avoidable. This article provides you with a basic understanding of how the system, particularly the servo unit, works and what you can do to improve it and prolong its working life. In an a future issue we'll show you how to repair a faulty servo unit.

Automatic climate control system problems usually involve the servo unit, which translates commands received from the driver to control the flow of coolant and air in the heating and air conditioning systems. The servo was originally supplied to Chrysler, which discontinued its use in 1972. Mercedes-Benz cars first used the unit in the 1976 model year. Models/years with this servo are:

- 1976: 116 sedan series only
- 1977: 116 series plus 300D and 280E
- 1978: same as 1977, plus SL models
- 1979: same as 1978, plus all 123-series

An improved system replaced the servo for the 1981 model year except the on SL, which got the new system for 1982. If your car has the old servo, replacement can cost from \$175 to \$400, depending upon who does the work.

Servo Function

The desired interior air temperature is maintained as a result of various control signals provided by a sensor chain and amplifier shown in Figure 1. The sensor chain consists of four components connected in series (one after the other). The first is the servo assembly (1), containing

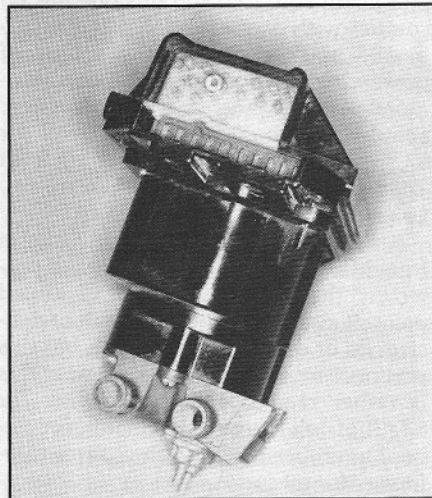

Climate control servo has connections for vacuum (top), electrical and coolant (bottom) lines.

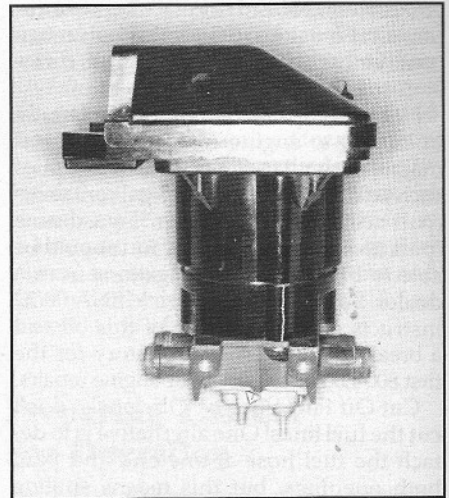

Side view of servo shows typical crack in center housing (white line).

a motor-driven feedback potentiometer, a water regulating valve, a blower speed switch and a vacuum distributor. The other three components in the chain are the temperature selector wheel (2), the in-car air temperature sensor (3) and the ambient (outside) air temperature sensor (4). The amplifier (5) contains a fixed resistance, against which the varying resistance of the sensor chain is constantly measured.

Let's look at the sensor chain components:

Servo Assembly (1): To maintain the selected air temperature, the servo assembly (see Figure 2) continually adjusts air and coolant flow. It contains an electric motor-driven gear train activated by signals from the amplifier. The servo adjusts air temperature through three functions:

a) adjustment of an integral hot water valve to control hot water flow through the heater core. Coolant enters and leaves the servo through the four tubes in the lower housing.

b) regulation of blower speed through a remotely-mounted resistor block. This resistor block is fed current by a switch arm in the sensor which moves over contacts as the servo shifts from one mode to another, thus varying blower speed.

c) adjustment of an integral vacuum distributor valve which controls the combinations of air flap positions for outside air intake, foot well air, dash air and defroster air. These flaps are operated by vacuum distributed by the valve, which has several positions.

Vacuum distributor (round); blower switch arm (dark, left) and contact plate (right).

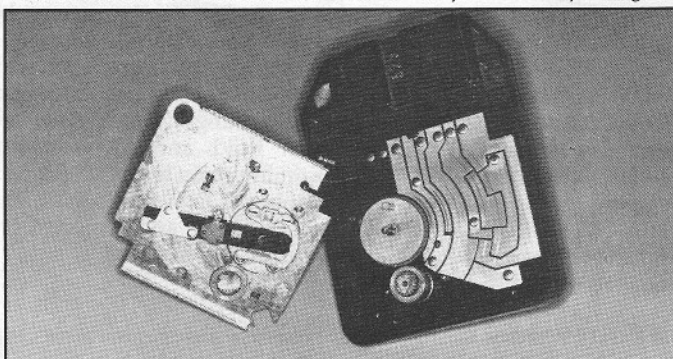

Coolant valve fits into center housing, controls flow through lower housing (right).

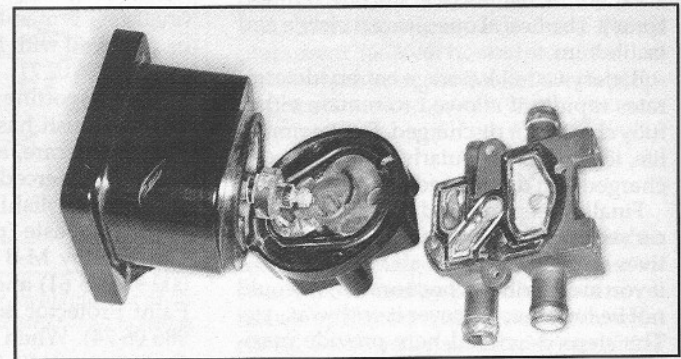

FDB

A cold engine lockout switch in the lower section of the servo unit prevents the blower from operating until the engine is warm enough to provide warm air for heating. This bi-metallic switch directs vacuum to the master blower switch (activating it) at temperatures above 104°F and disconnects vacuum at temperatures below 68°F (disabling it). The cold engine lockout switch responds to both ambient air and engine coolant temperatures.

The servo also contains a feedback potentiometer, part of the sensor chain. This potentiometer increases in resistance as

Amplifier (5): The amplifier measures the total resistance of the sensor chain (the selector wheel potentiometer, the in-car sensor, the ambient temperature sensor and the servo feedback potentiometer). This total resistance is compared with a fixed resistance within the amplifier. If the two are unequal, the amplifier actuates the servo motor until both resistances become equal. The in-car and ambient air temperature sensors allow for continuous adjustment of the servo via the amplifier. In this way, the selected temperature is maintained despite changing in-car and am-

crack due to stresses caused by assembly screws, which do not permit expansion of the center housing as it heats. When this center housing cracks, coolant may leak from the unit. If undetected or ignored, coolant loss can cause engine failure due to overheating, frequently meaning a complete engine rebuild or replacement.

There are two ways to repair the center section. First, Mercedes-Benz sells a replacement kit, described in the September/October 1983 issue of *The STAR*. Besides a new plastic center section and various other parts, this kit contains spring washers to fit under the screw heads so that the center housing may expand, reducing the possibility of over-stressing and cracking the part. The other alternative is to use an aftermarket kit with an aluminum center section, more resistant to cracking than the original part.

Internal Leakage: An O-ring on the water valve shaft may fail, allowing engine coolant to reach the servo motor and gear train. This will eventually corrode the gears and cause the motor, which is quite powerful, to strip the primary gear in the gear train. The leaky O-ring is virtually impossible to replace, as it is held in place by a "one-way" assembly washer. Internal leakage is evidenced either by coolant leaking from any of the four drain holes just above the center housing or by moisture on the blower switch arm contacts (after the top cover is removed).

Water Valve Separated from Shaft: Dirty engine coolant can foul the close tolerances in the water flow regulating valve. This results in more friction and thus more force being applied to the valve connector clip. When the clip fails, the water valve will separate from its shaft. The servo then appears to operate normally, but there is no change in air temperature (assuming that the air conditioning system is OK). Blower speeds seem to change normally, and the air flaps operate, but the system delivers air at only one temperature (warm or cool, depending on the position of the valve at failure).

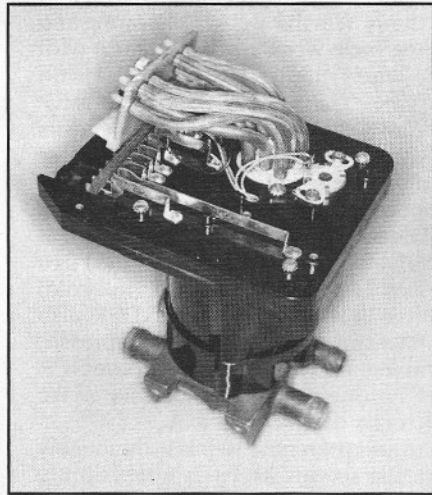

Removing top cover shows lines entering vacuum distributor; electrical connections drop through top plate.



Motor, gears below top plate activate coolant valve, contact arm, vacuum distributor.

the servo enters the cooling mode and decreases in resistance as the servo enters the heating mode.

Temperature Selector Wheel Potentiometer (2): This device changes resistance as you move the temperature selector wheel. When a higher temperature is selected, resistance increases; when a lower temperature is selected, resistance decreases. Since the potentiometer is in series with the other components in the sensor chain, the resistance of the entire chain is altered accordingly.

In-Car Temperature Sensor (3): The in-car sensor is a temperature-sensitive resistor called a thermistor. Located in the car's interior, it can accurately measure air temperature. As interior temperature rises, the sensor's resistance decreases; as temperature falls, resistance increases. Again, this affects the resistance of the entire sensor chain. To reduce response time and increase control accuracy, interior air is drawn over the in-car sensor when the blower is running. Air is conducted over the sensor via a tube connected to the suction side of the blower housing.

Ambient Temperature Sensor (4): The ambient air sensor is also a thermistor and is in the outside air intake duct. Its operation is identical to that of the in-car sensor except that it measures the temperature of incoming outside air. Outside air is drawn over the sensor when the blower is in operation.

bient air temperatures. The feedback potentiometer in the servo assembly also aids the amplifier in maintaining a selected air temperature by limiting the response of the servo, preventing over-control.

What Can Go Wrong?

The following failures have been noted in servos:

Coolant Leakage from Cracked Center Housing: The plastic center housing may

Figure 1: Automatic climate control sensor chain.

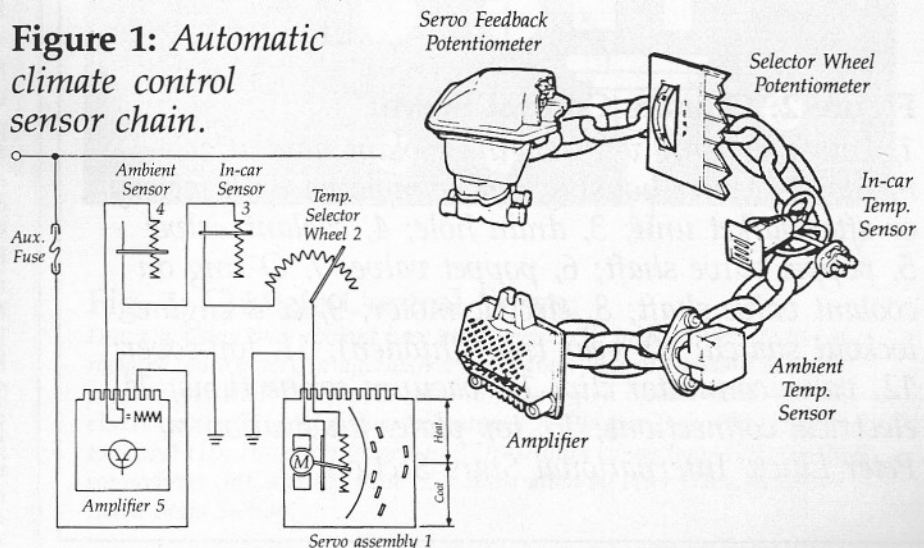

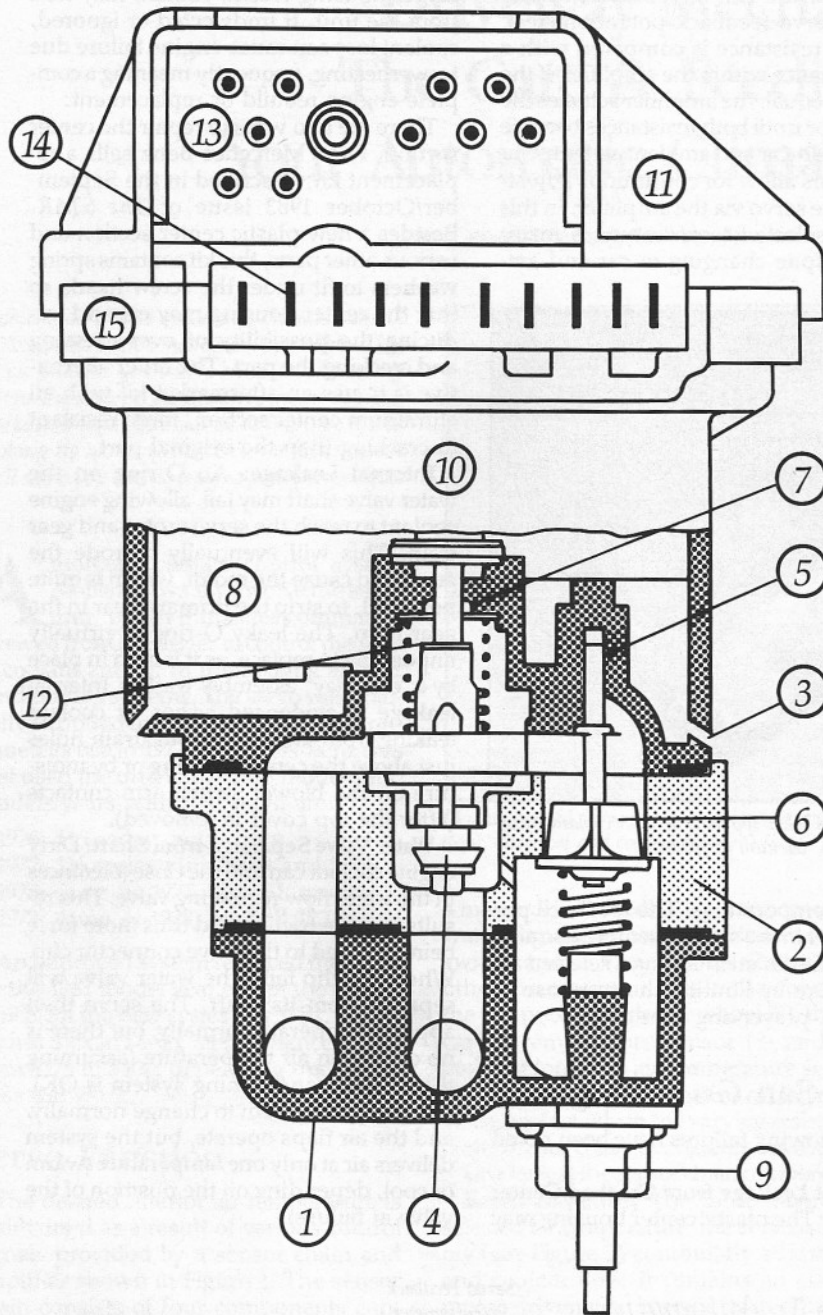

Figure 2: Climate Control Servo:

1, Lower housing with engine coolant hose attachments; 2, center housing can be replaced with factory or aftermarket unit; 3, drain hole; 4, coolant valve; 5, poppet valve shaft; 6, poppet valve; 7, O-ring on coolant valve shaft; 8, electric motor; 9, cold engine lockout switch; 10, gear train (hidden); 11, top cover; 12, valve connector clip; 13, vacuum connections; 14, electrical connections; 15, top plate. Illustration by Peter Lilicy, International Stars Section.

Open Servo Feedback Potentiometer: This is a rare failure and hard to diagnose. On my car, in Auto Low or Auto High with the compressor switch on, the system would deliver ice cubes at the dash vents. Adjusting the temperature selector wheel had no effect. If the compressor was switched off, the wheel had to be turned above 80°F before any heating took place. The potentiometer is under the servo's top cover and is driven by the gear train.

Preventive Maintenance

You can help prevent O-ring failure and separation of the water valve shaft. First, run the system through a full heating and cooling cycle weekly in accordance with the owner's manual (good practice with any car). This moves the water valve through a full stroke to clean out deposits which may be accumulating in the valve chamber, creating friction and valve connector clip failure. Operate the automatic climate control in the Defrost mode for at least five minutes. Then select Auto High or Auto Low and dial in 65°F (full cold) for five minutes. Selecting DEF also operates the air conditioning compressor if ambient air temperature is above 38°F, thus lubricating the compressor seals, which can dry out and leak.

The next preventive step is to thoroughly flush the servo with fresh water during your bi-annual anti-freeze change. DBAG recommends changing engine coolant every two years. If you follow this schedule, your servo will probably last longer — and so will your engine. Some servos that we have opened look as if the coolant has never been changed. The water passages were almost completely plugged, and the water valve was stuck, causing the motor drive gear to be stripped or the valve connector clip to fail.

Cracked center housings are hard to prevent. On rebuilding, use spring washers on the center housing screws to accommodate heat expansion. Or use the aluminum center housing mentioned above.

Useful Information

The servo assembly was made by Ranco in Mt. Vernon, Ohio for use on some Chrysler cars of the early 1970's. Its Chrysler part number is 3441530. Cost is about \$300 at Mercedes-Benz dealers and about \$215 at Chrysler dealers, or the part can be ordered from some independent parts suppliers for about \$175. The Mercedes-Benz plastic center section repair kit is part number 000 830 01 98 and costs about \$40. Installation is covered by MBNA Service Information 83/38. The aluminum center housing is available from Jodel Associates, 3334 E. Coast Highway, Suite 290, Corona del Mar, California 92625; (714) 640-4053 at a cost of \$49.95. If you have other questions or need more information, I can be reached at (615) 482-7260.